

III. Metabolism - Gluconeogenesis

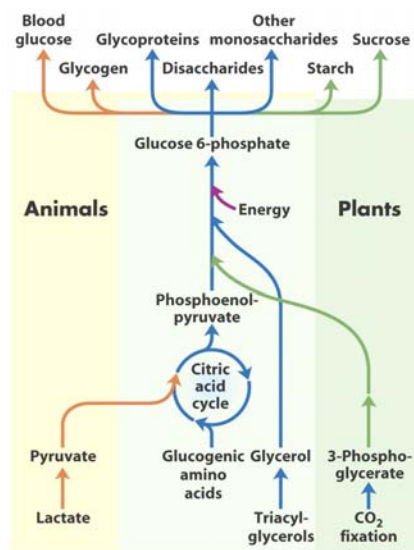

Carbohydrate Synthesis



Lactate, pyruvate and glycerol are the important 3C compounds that feed gluconeogenesis.

Glucogenic amino acids – catabolized to pyruvate, and other citric acid cycle compounds can enter gluconeogenesis.

Photosynthetic organisms use the pathway to fix CO₂.

Occurs in the liver of mammals !

Glucogenic Amino Acids ?

TABLE 14-4 Glucogenic Amino Acids, Grouped by Site of Entry

Pyruvate	Succinyl-CoA
Alanine	Isoleucine*
Cysteine	Methionine
Glycine	Threonine
Serine	Valine
Threonine	Fumarate
Tryptophan*	Phenylalanine*
α-Ketoglutarate	Tyrosine*
Arginine	Oxaloacetate
Glutamate	Asparagine
Glutamine	Aspartate
Histidine	
Proline	

Note: All these amino acids are precursors of blood glucose or liver glycogen, because they can be converted to pyruvate or citric acid cycle intermediates. Of the 20 common amino acids, only leucine and lysine are unable to furnish carbon for net glucose synthesis. *These amino acids are also ketogenic (see Fig. 18-21).

The Cori Cycle

When a working muscle goes anaerobic, the generated lactate is released and is transported to the liver via the bloodstream.

In the liver Lactate is converted to glucose (gluconeogenesis).

Glucose produced in the liver is made available, through the bloodstream, to other tissues e.g. muscle.

If muscle contraction ceases, glucose is still transported to the muscle → conversion to glycogen.

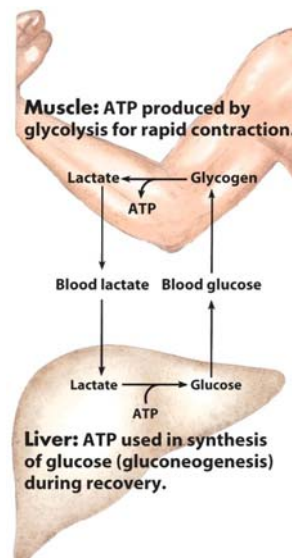

Glycolysis Again

TABLE 14-2 Free-Energy Changes of Glycolytic Reactions in Erythrocytes

Glycolytic reaction step	$\Delta G'^{\circ}$ (kJ/mol)	ΔG (kJ/mol)
① Glucose + ATP \longrightarrow glucose 6-phosphate + ADP	-16.7	-33.4
② Glucose 6-phosphate \rightleftharpoons fructose 6-phosphate	1.7	0 to 25
③ Fructose 6-phosphate + ATP \longrightarrow fructose 1,6-bisphosphate + ADP	-14.2	-22.2
④ Fructose 1,6-bisphosphate \rightleftharpoons dihydroxyacetone phosphate + glyceraldehyde 3-phosphate	23.8	0 to -6
⑤ Dihydroxyacetone phosphate \rightleftharpoons glyceraldehyde 3-phosphate	7.5	0 to 4
⑥ Glyceraldehyde 3-phosphate + P_i + NAD ⁺ \rightleftharpoons 1,3-bisphosphoglycerate + NADH + H ⁺	6.3	-2 to 2
⑦ 1,3-Bisphosphoglycerate + ADP \rightleftharpoons 3-phosphoglycerate + ATP	-18.8	0 to 2
⑧ 3-Phosphoglycerate \rightleftharpoons 2-phosphoglycerate	4.4	0 to 0.8
⑨ 2-Phosphoglycerate \rightleftharpoons phosphoenolpyruvate + H ₂ O	7.5	0 to 3.3
⑩ Phosphoenolpyruvate + ADP \longrightarrow pyruvate + ATP	-31.4	-16.7

Note: $\Delta G'^{\circ}$ is the standard free-energy change, as defined in Chapter 13 (p. 491). ΔG is the free-energy change calculated from the actual concentrations of glycolytic intermediates present under physiological conditions in erythrocytes, at pH 7. The glycolytic reactions bypassed in gluconeogenesis are shown in red. Biochemical equations are not necessarily balanced for H or charge (p. 506).

Gluconeogenesis

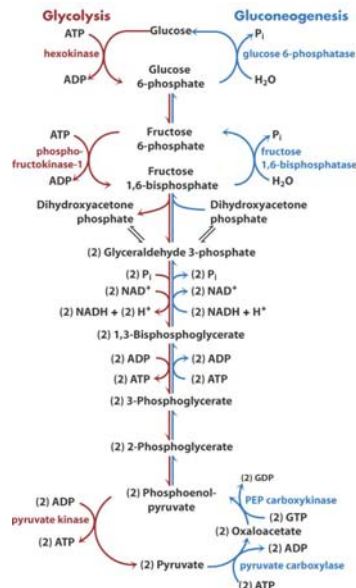

Glycolysis and gluconeogenesis share 7 of 10 steps

The reactions of hexokinase, PFK-1 and pyruvate kinase are essentially irreversible *in vivo*.

These steps have to be bypassed in gluconeogenesis.

The gluconeogenesis enzyme reactions are also irreversible *in vivo*.

Both are reciprocally regulated, cytosolic pathways. Metabolite flux is always one way or the other.

Gluconeogenesis Reactions

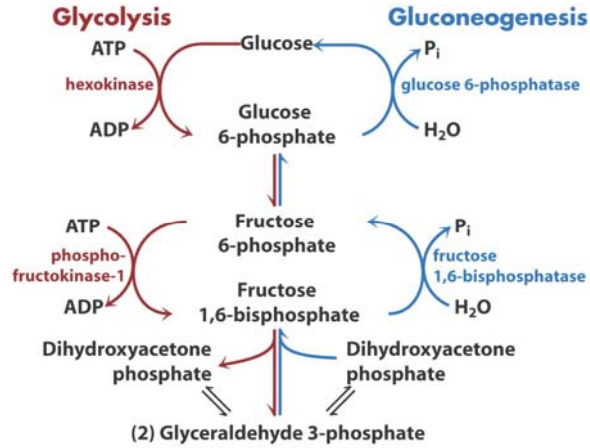

Glucose 6-phosphatase and Fructose 1,6- bisphosphatase catalyze simple hydrolysis reactions. → strongly favorable

Gluconeogenesis Reactions

Conversion of pyruvate to PEP is complex.

Oxaloacetate is a citric-acid cycle metabolite → occurs in mitochondria

Pyruvate must be transported into the mitochondrion to enter gluconeogenesis

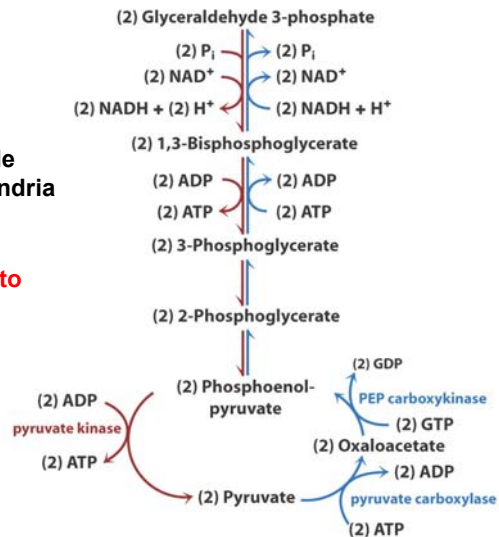

Gluconeogenesis – Step 1

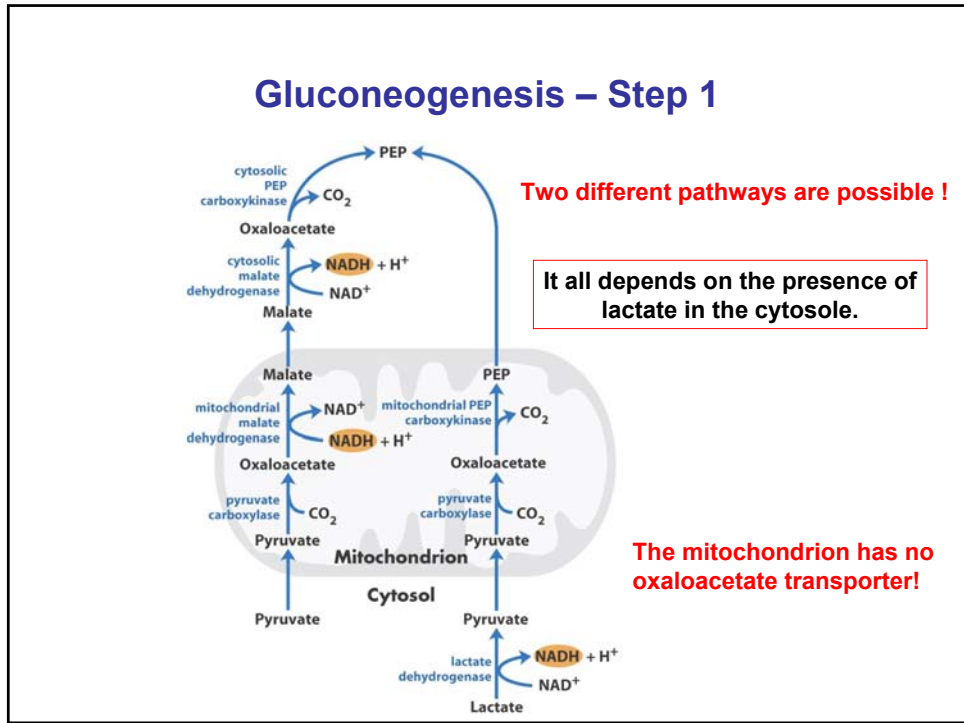

Gluconeogenesis – Step 1

Pyruvate carboxylase

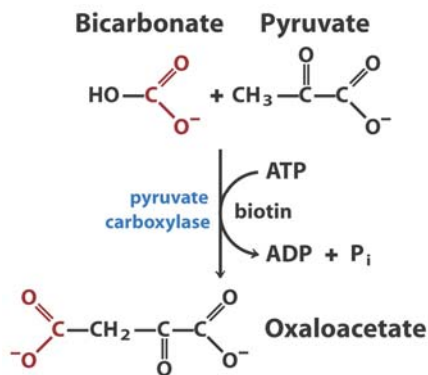

1 ATP is used !

Gluconeogenesis – Step 1

Pyruvate carboxylase

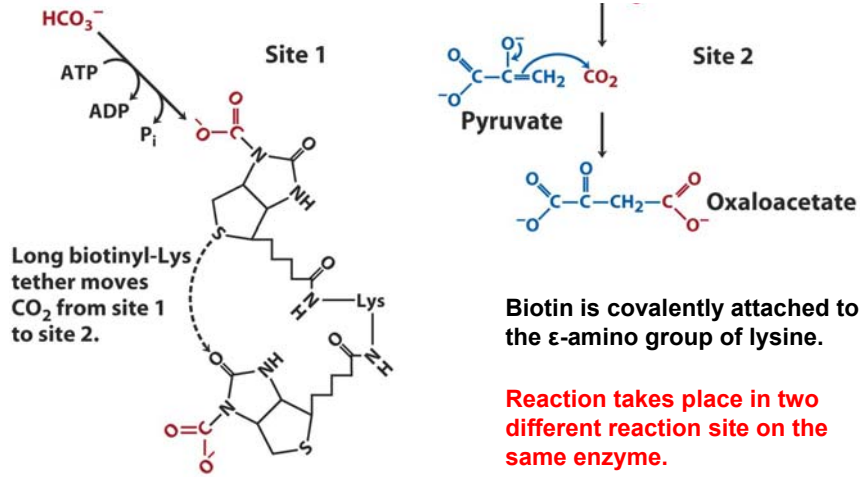

Gluconeogenesis – Step 1

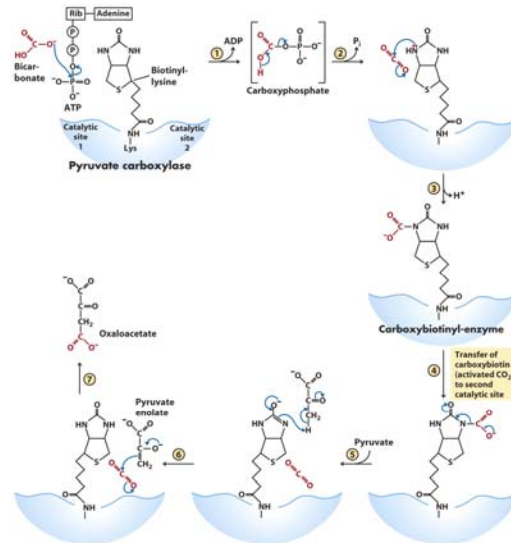

Gluconeogenesis – Step 1

PEP carboxykinase

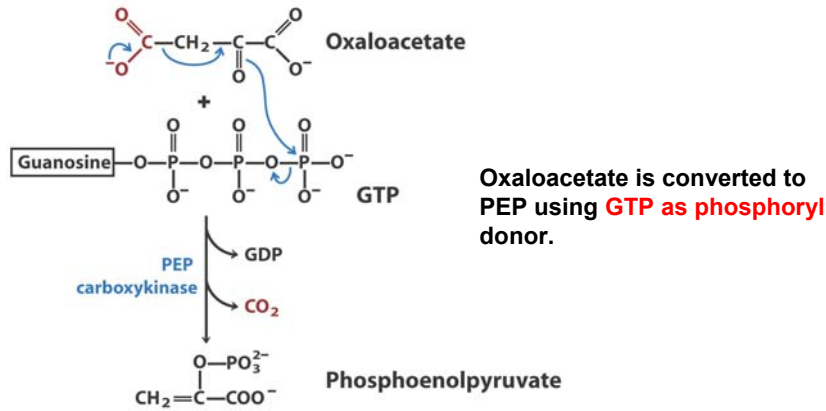

Gluconeogenesis – Step 1

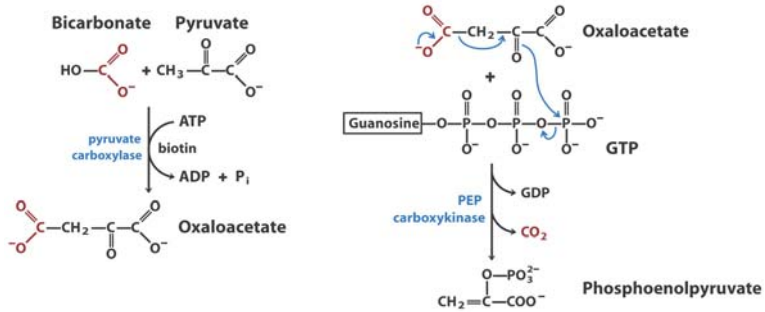

Net costs for the reaction are 2 ATP

The PEP carboxykinase reversibly exchanges high energy bonds

$$\Delta G^\circ = 0.9 \text{ kJ/mol}$$

but under cellular conditions $\Delta G = -25 \text{ kJ/mol}$

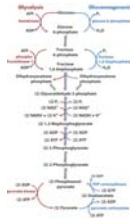

Summary

TABLE 14-3 Sequential Reactions in Gluconeogenesis Starting from Pyruvate

Pyruvate + HCO ₃ ⁻ + ATP → oxaloacetate + ADP + P _i	×2
Oxaloacetate + GTP ⇌ phosphoenolpyruvate + CO ₂ + GDP	×2
Phosphoenolpyruvate + H ₂ O ⇌ 2-phosphoglycerate	×2
2-Phosphoglycerate ⇌ 3-phosphoglycerate	×2
3-Phosphoglycerate + ATP ⇌ 1,3-bisphosphoglycerate + ADP	×2
1,3-Bisphosphoglycerate + NADH + H ⁺ ⇌ glyceraldehyde 3-phosphate + NAD ⁺ + P _i	×2
Glyceraldehyde 3-phosphate ⇌ dihydroxyacetone phosphate	
Glyceraldehyde 3-phosphate + dihydroxyacetone phosphate ⇌ fructose 1,6-bisphosphate	
Fructose 1,6-bisphosphate → fructose 6-phosphate + P _i	
Fructose 6-phosphate ⇌ glucose 6-phosphate	
Glucose 6-phosphate + H ₂ O → glucose + P _i	
Sum: 2 Pyruvate + 4ATP + 2GTP + 2NADH + 2H ⁺ + 4H ₂ O → glucose + 4ADP + 2GDP + 6P _i + 2NAD ⁺	

Pentose Phosphate Pathway

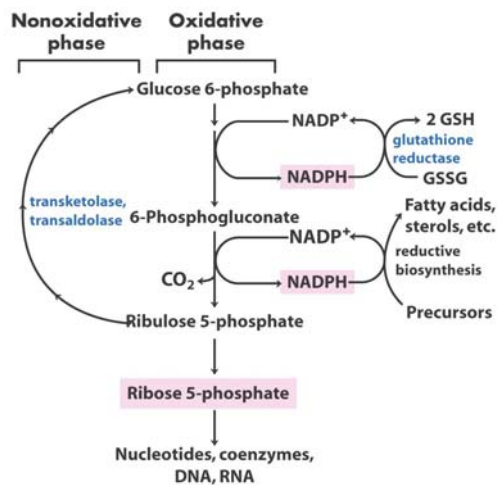

Alternative path to oxidize Glucose.

The electron acceptor is NADP⁺.

NADPH is needed for reductive biosynthesis.

Products are pentose phosphates.

High amounts of NADPH prevent oxidative damage to proteins (red blood cells, cornea).

Pentose Phosphate Pathway – Oxidative Phase

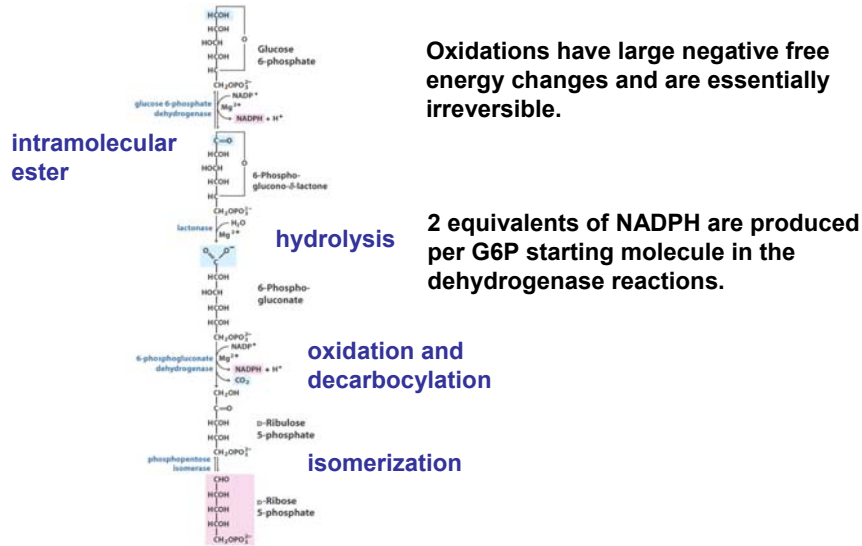

Pentose Phosphate Pathway – Oxidative Phase

Intramolecular ester

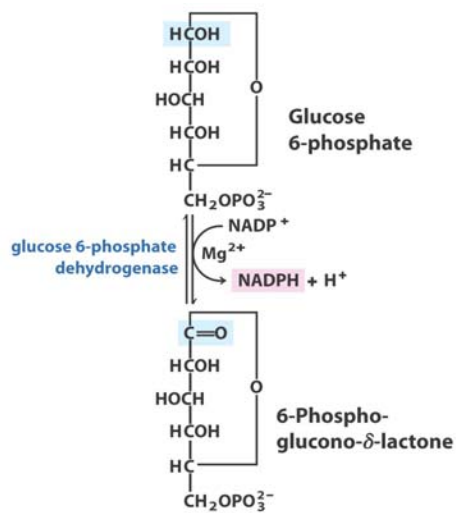

Pentose Phosphate Pathway – Oxidative Phase

Hydrolysis

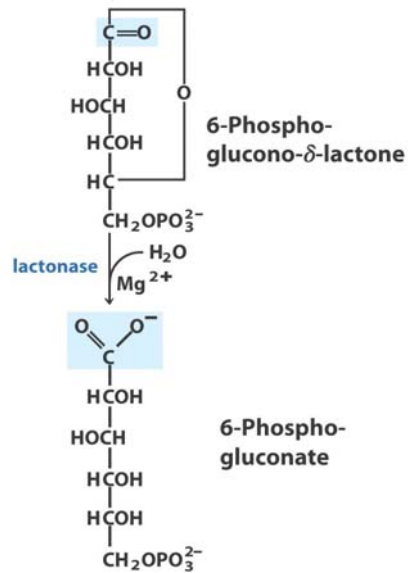

Pentose Phosphate Pathway – Oxidative Phase

Oxidation and decarboxylation

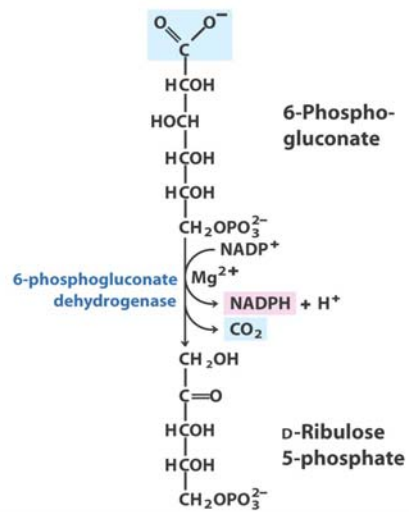

Pentose Phosphate Pathway – Oxidative Phase

Isomerisation

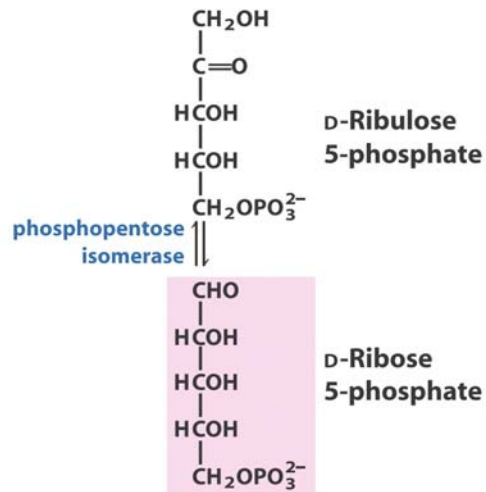

Pentose Phosphate Pathway – Oxidative Phase

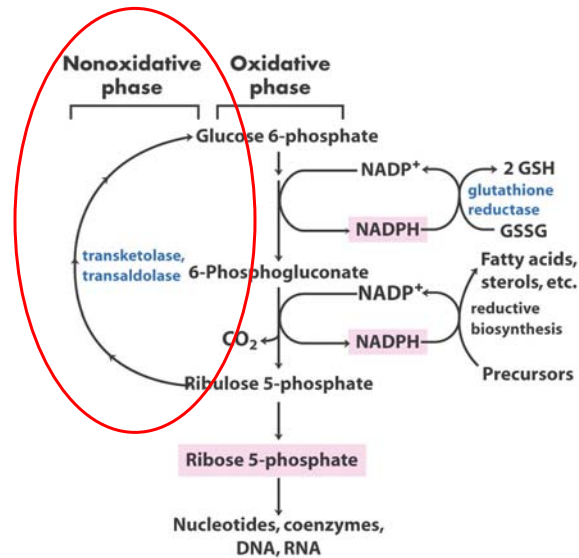

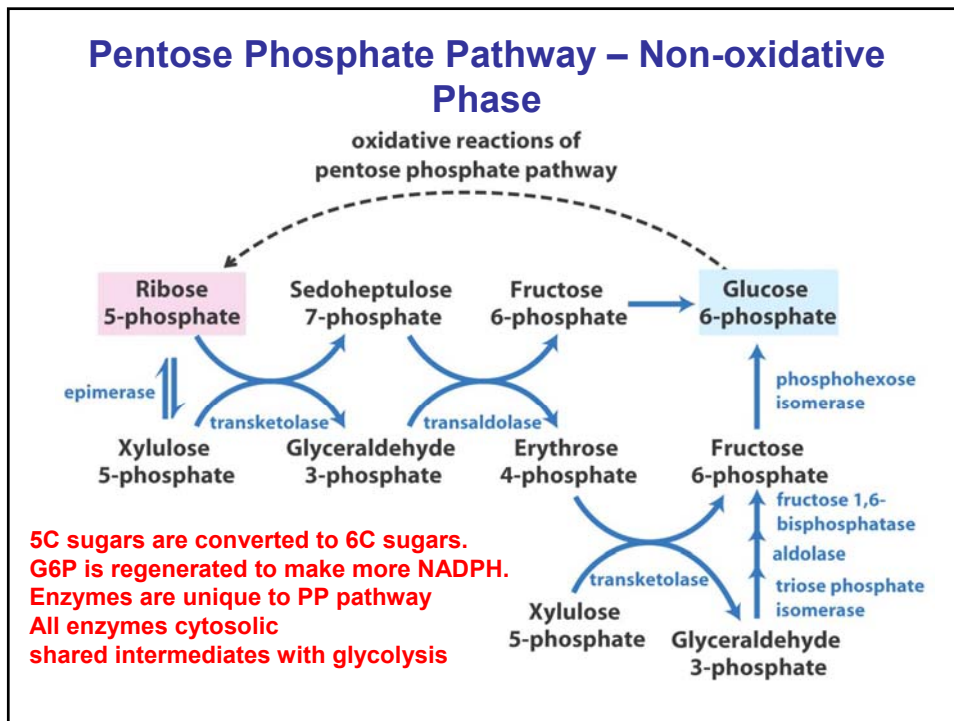
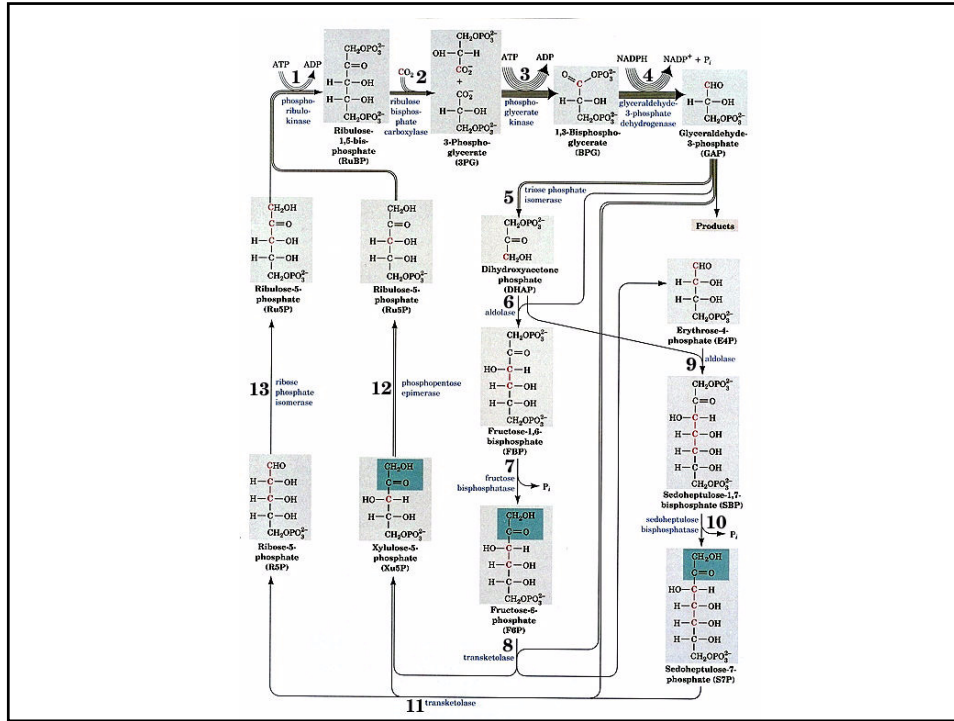

Nonoxidative Reactions of the Pentose Phosphate Pathway

5 hexoses (6C) are made from 6 pentoses (5C)

Every reaction shown here is reversible!

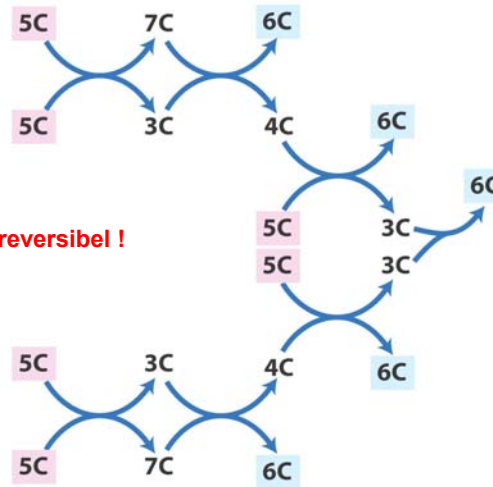

Epimerase

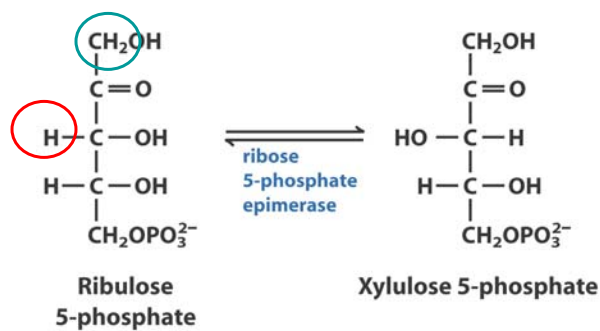

Reaction is similar to the ribose 5-phosphate isomerase: enediol intermediate.

In the epimerase reaction a proton is abstracted from C3 and added afterwards, resulting in an inverted configuration on the carbon atom.

Transketolase

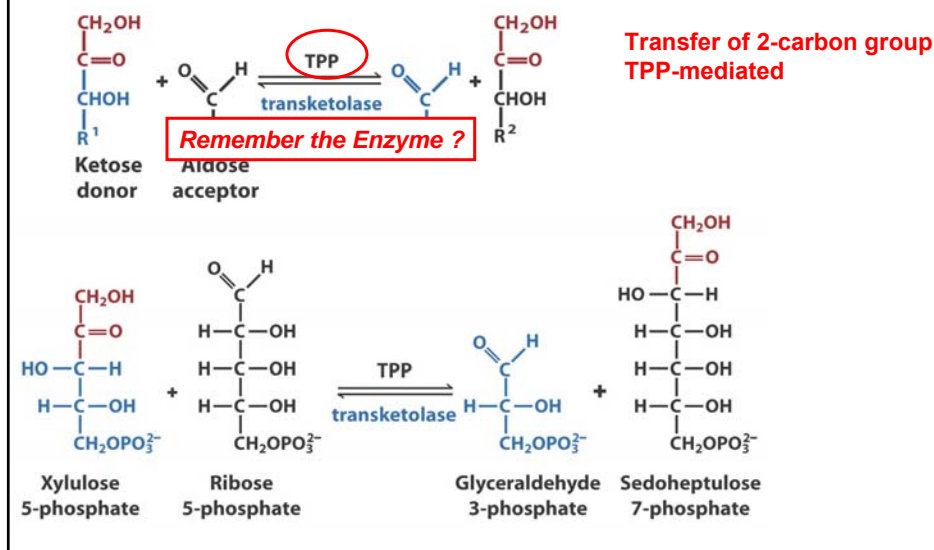

Thiamine Deficiency

The ability of TTP's thiazolium ring to add carbonyl groups and act as an "electron sink" makes it the coenzyme most utilized in α -keto acid decarboxylations.

TABLE 14-1 Some TPP-Dependent Reactions

Enzyme	Pathway(s)	Bond cleaved	Bond formed
Pyruvate decarboxylase	Ethanol fermentation	$\text{R}^1-\text{C}(=\text{O})-\text{C}(=\text{O})-\text{O}^-$	$\text{R}^1-\text{C}(=\text{O})-\text{H}$
Pyruvate dehydrogenase α -Ketoglutarate dehydrogenase	Synthesis of acetyl-CoA Citric acid cycle	$\text{R}^2-\text{C}(=\text{O})-\text{C}(=\text{O})-\text{O}^-$	$\text{R}^2-\text{C}(=\text{O})-\text{S-CoA}$
Transketolase	Carbon-assimilation reactions Pentose phosphate pathway	$\text{R}^3-\text{C}(=\text{O})-\text{C}(\text{OH})-\text{R}^4$	$\text{R}^3-\text{C}(=\text{O})-\text{C}(\text{OH})-\text{R}^5$

Thiamin (vitamin B1) is neither synthesized nor stored in significant amounts by vertebrates. Deficiency in humans results in an ultimately fatal condition known as beriberi.

Transaldolase

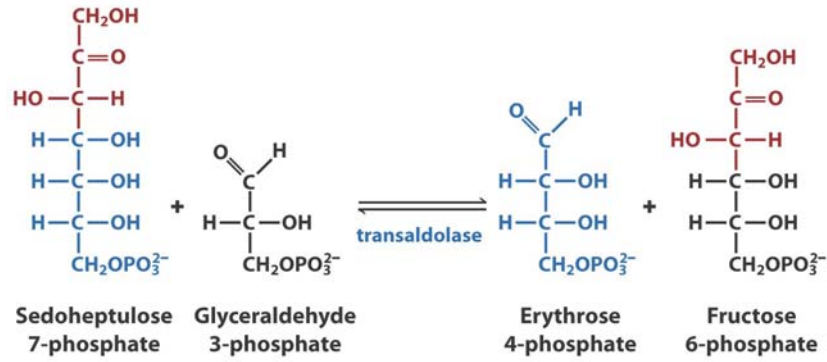

Transfer of 3-carbon unit; similar to aldolase reaction in glycolysis.

Short Reminder – Class I Aldolase

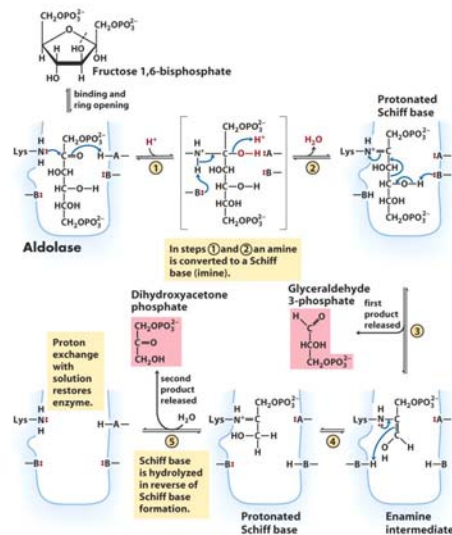

Mechanistic Similarity !

Transketolase

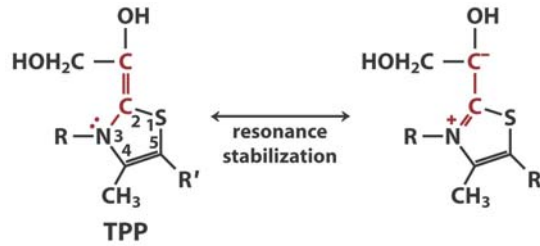

TPP stabilizes the two-carbon carbanion

Transaldolase

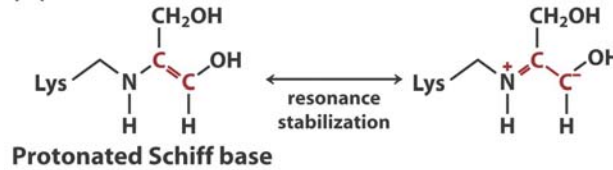

Schiff base stabilizes the three-carbon carbanion

Regulation

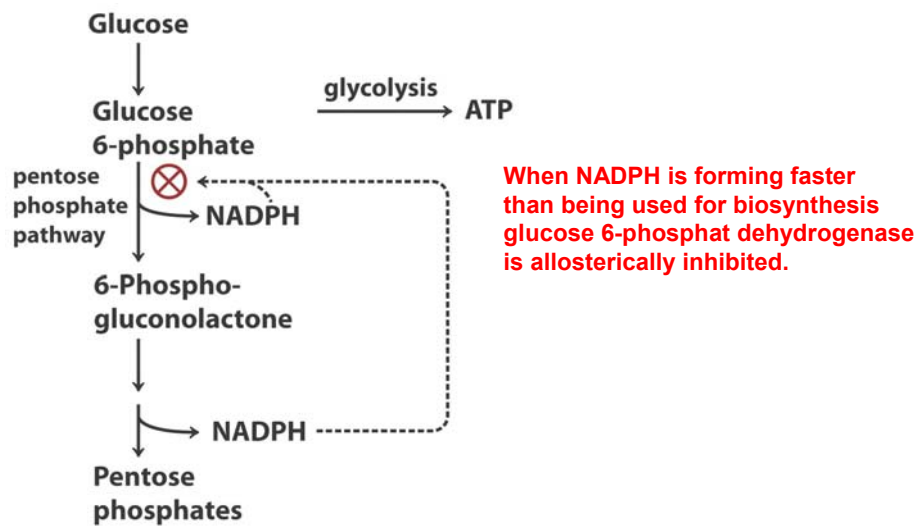

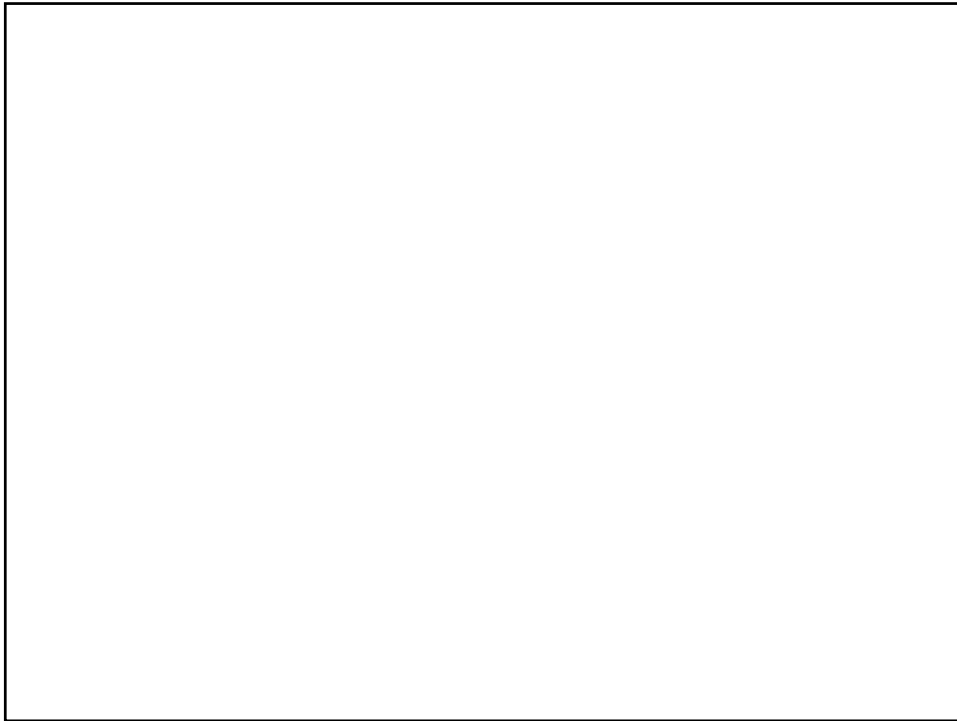

Some Questions

During strenuous exercise, the NADH formed in the glyceraldehyde 3-phosphate dehydrogenase reaction in skeletal muscle must be reoxidized to NAD^+ if glycolysis is to continue.

The most important reaction involved in reoxidation of NADH is:

- A dehydroxyacetone phosphate \rightarrow glycerol 3-phosphate
- B glucose 6-phosphate \rightarrow fructose 6-phosphate
- C oxaloacetate \rightarrow malate
- D pyruvate \rightarrow lactate

Some Questions

In an anaerobic muscle preparation, lactate formed from glucose labeled in C-3 and C-4 would be labeled in:

- A all three carbon atoms
- B only the carbon atom carrying the OH
- C only the carboxyl carbon atom
- D only the methyl carbon atom
- E the methyl and carboxyl carbon atoms

Some Questions

Which of the following statements about the pentose phosphate pathway is *incorrect*?

- A It generates CO₂ from C-1 of glucose.
- B It involves the conversion of an aldohexose to an aldopentose.
- C It is principally directed toward the generation of NADPH.
- D It requires the participation of molecular oxygen.

Reading

Chapter 16

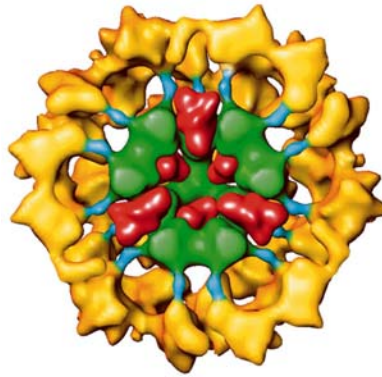

The Citric Acid Cycle